



Spare parts catalogue
E-SCOOTER TX1-TX2 MY21

Index

0 - Models (E-SCOOTER TX1-TX2 MY21)	3
1 - Handlebar (E-SCOOTER TX1-TX2 MY21)	5
2 - Fork (E-SCOOTER TX1-TX2 MY21)	7
3 - Frame (E-SCOOTER TX1-TX2 MY21)	9
4 - Wiring (E-SCOOTER TX1-TX2 MY21)	11
5 - Bodywork (E-SCOOTER TX1-TX2 MY21)	13



TX1 TX2 E - SCOOTER

Grey



TX1 TX2 E - SCOOTER

Black



TX1 TX2 E - SCOOTER

Blue



TX1 TX2 E - SCOOTER

Red

#	Code	Description	Specification	UM	Qty
---	------	-------------	---------------	----	-----



0 - Models (E-SCOOTER TX1-TX2 MY21)

0-TX1_TX2_MY21
4/14

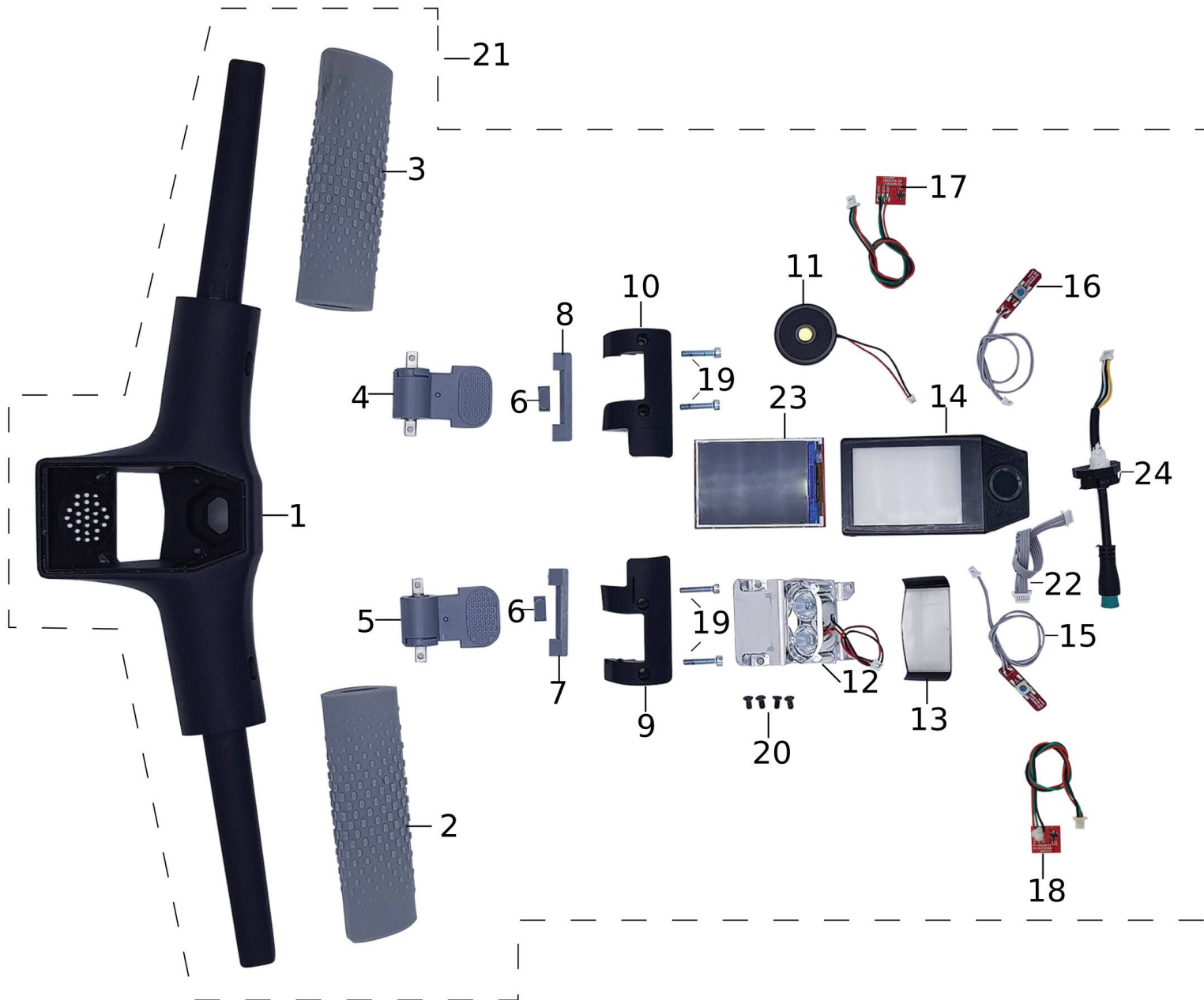

#	Code	Description	Specification	UM	Qty
1	TX001001	HANDLEBAR		pz	1
2	TX002001	HANDGRIP		pz	1
3	TX003001	HANDGRIP		pz	1
4	TX004001	CONTROL		pz	1
5	TX005001	CONTROL		pz	1
6	TX006001	KEY		pz	2
7	TX007001	PIN		pz	1
8	TX008001	PIN		pz	1
9	TX009001	COVER		pz	1
10	TX010001	COVER		pz	1
11	TX011001	CLAXON		pz	1
12	TX012001	TAIL		pz	1
13	TX013001	GLASS		pz	1
14	TX014001	DASHBOARD		pz	1
15	TX015001	CHIP CLAXON		pz	1
16	TX016001	CHIP FUNCTION		pz	1
17	TX017001	CHIP ACCELERATOR		pz	1
18	TX018001	CHIP BRAKE		pz	1
19	TX019001	SCREW		pz	4
20	TX020001	SCREW		pz	4
21	TX021001	HANDLEBAR		pz	1
22	TX022001	CABLE		pz	1
23	TX023001	CHIP DASHBOARD		pz	1
24	TX024001	CABLE		pz	1

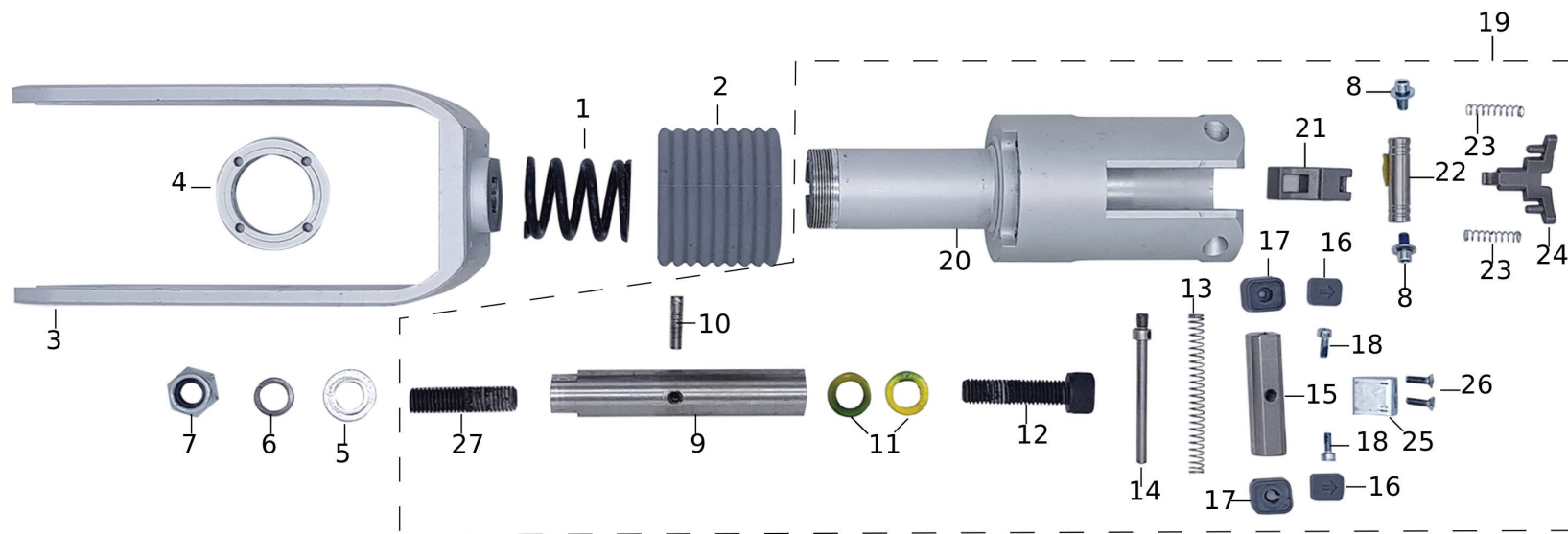

#	Code	Description	Specification	UM	Qty
1	TX025001	SPRING		pz	1
2	TX026001	BELLOWS		pz	1
3	TX027001	FORK STEMS		pz	1
4	TX028001			pz	1
5	TX029001	WASHER, THRUST 1		pz	1
6	TX030001	WASHER		pz	1
7	TX031001	NUT		pz	1
8	TX032001	SCREW		pz	2
9	TX033001	PIN		pz	1
10	TX034001	PIN		pz	1
11	TX035001	WASHER		pz	1
12	TX036001	BOLT		pz	1
13	TX037001	MOLLA		pz	1
14	TX038001	PIN		pz	1
15	TX039001			pz	1
16	TX040001			pz	2
17	TX041001			pz	2
18	TX042001	SCREW		pz	4
19	TX043001	JOINT		pz	1
20	TX044001	JOINT		pz	1
21	TX045001			pz	1
22	TX046001			pz	1
23	TX047001	MOLLA		pz	2
24	TX048001	CASING		pz	1
25	TX049001			pz	1
26	TX055001	SCREW		pz	2
27	TX050001	SCREW		pz	2





#	Code	Description	Specification	UM	Qty
1	TX051001	SCREW		pz	3
2	TX052001	SCREW		pz	4
3	TX053001	SCREW		pz	4
4	TX054001	PLATE		pz	1
5	TX055001	SCREW		pz	19
6	TX056001	FLOOR		pz	1
7	TX057001	AXIS		pz	1
8	TX058001	STAND		pz	1
9	TX059001	BEARING		pz	2
10	TX060001	BOLT		pz	1
11	TX061001	COVER		pz	1
12	TX062001	HOLDER, CLUTCH CABLE		pz	1
13	TX063001	HOLDER, CLUTCH CABLE		pz	1
14	TX064001	HOLDER, CLUTCH CABLE		pz	1
15	TX103001	GUARNIZIONE PIANALE 1,5MT TX2		pz	1

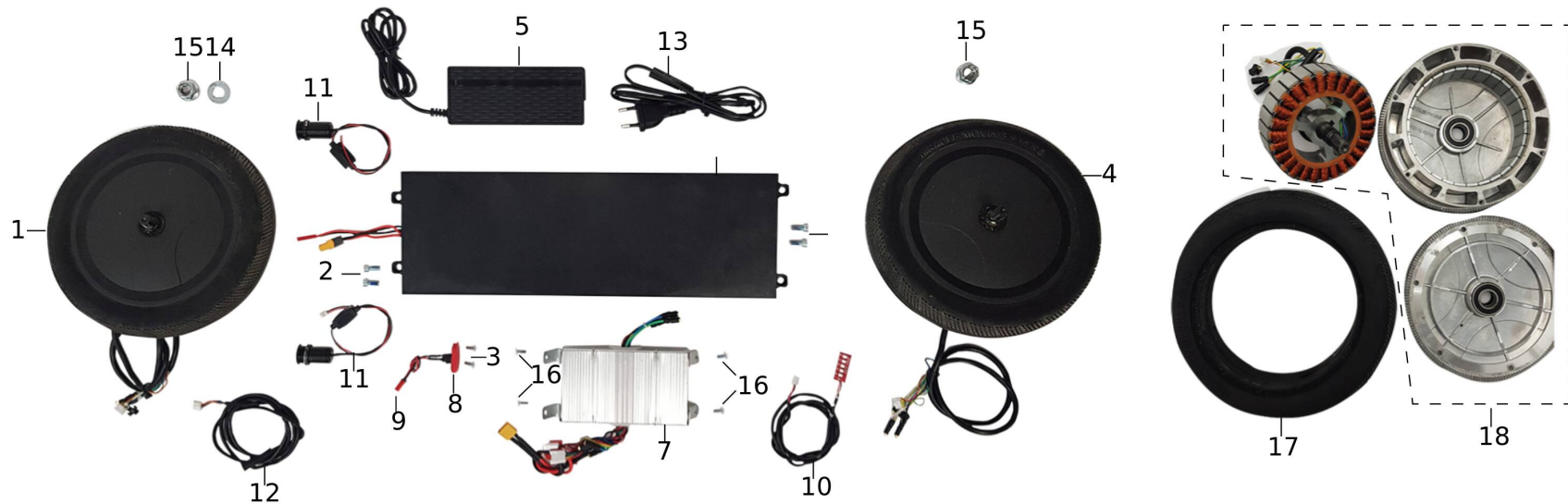

#	Code	Description	Specification	UM	Qty
1	TX065001	WHEEL		pz	1
2	TX066001	SCREW		pz	2
3	TX067001	SCREW		pz	2
4	TX069001	WHEEL	TX2	pz	1
5	TX070001	CHARGER		pz	1
6	TX071001	BATTERY		pz	1
7	TX072001	CONTROL	TX1	pz	1
7	TX073001	CONTROL	TX2	pz	1
8	TX074001	CAP		pz	1
9	TX075001	CONNECTOR		pz	1
10	TX076001	TAIL		pz	1
11	TX077001	LIGHT		pz	2
12	TX078001	WIRE HARNESS ASSY		pz	1
13	TX079001	CABLE		pz	1
14	TX094001	WASHER, THRUST 1		pz	1
15	TX095001	NUT		pz	1
16	TX055001	SCREW		pz	4
17	TX068001	WHEEL		pz	1
18	TX105001	MOTORE RUOTA MONOPATTINO		pz	1

14

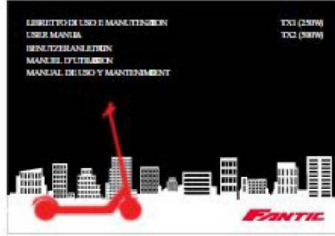

15

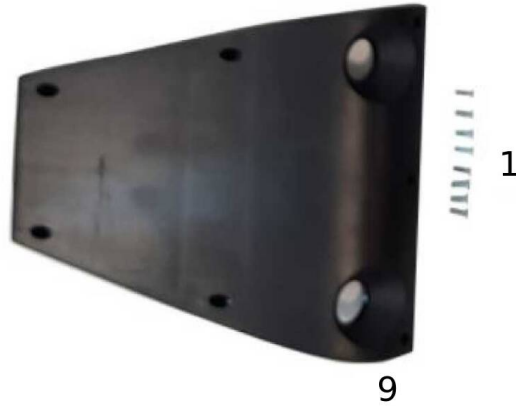

#	Code	Description	Specification	UM	Qty
1	TX080001	SCREW		pz	21
2	TX081001	FLOOR MAT		pz	1
3	TX082001	HOLDER		pz	1
4	TX083001	HOLDER		pz	1
5	TX084001	ADHESIVE		pz	2
6	TX085001	GLASS		pz	1
7	TX086001	HOLDER		pz	1
8	TX087001	MUDGUARD		pz	1
9	TX088001	COVER		pz	1
10	TX089001	MUDGUARD		pz	1
11	TX090001	HOLDER		pz	1
12	TX091001	HOLDER		pz	1
13	TX092001	ADHESIVES		pz	2
14	B0900101005	USER MANUAL FANTIC E SCOOTER MY21		pz	1
15	TX093001	BOX		pz	1
16	TX096001	SCREW		pz	2